

6K ATTACHMENT CYLINDERS

These attachment cylinders are designed for demanding applications and offer extended seal life even when work induced loads generate pressure spikes over 15,000 psi.

Design features for extending operating life:

1. Port closing cushion reduces impact at end of retract stroke.
2. Step cut wear rings act as pressure buffers as well as bearings.
3. Step Lock piston seal provides the longest seal life when pressures exceed 7,000 psi.
4. Taper allows for a larger thread diameter by increasing the contact area of piston to eliminate having the piston cold form over the rod.
5. Urethane U-Seal between the head and barrel extend operating life over an O-Ring and back up ring.
6. A Hallite 621 U-Seal with anti extrusion ring provides for excellent rod seal life.

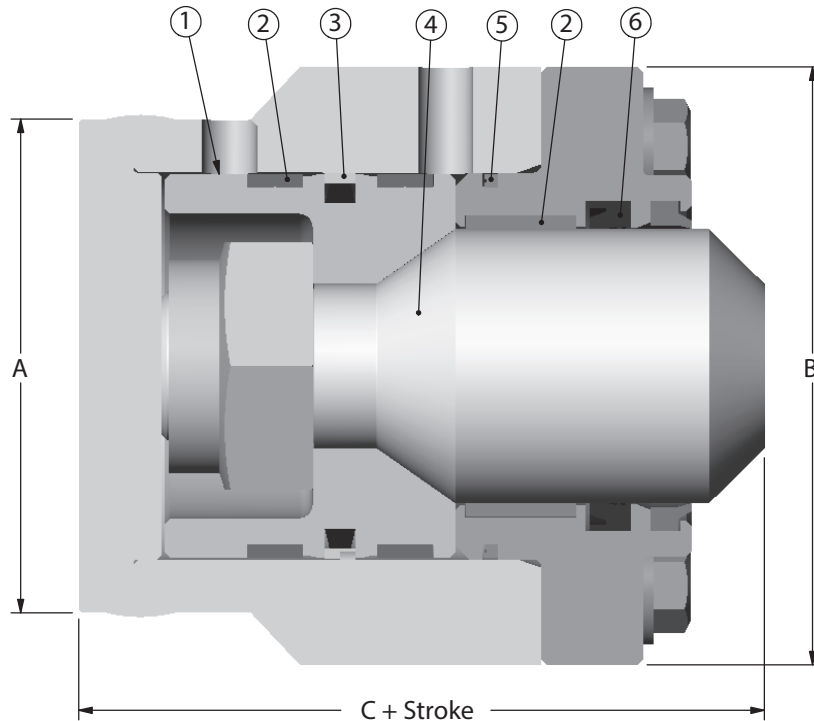

Quick Ship Sizes

Bore Diameter	Rod Diameter	Maximum Stroke	Maximum Extend Force	Maximum Retract Force	A	B	C
4.025	2.750	42"	191,000 lbs	115,000 lbs	5.00"	5.95"	7.12"
5.025	3.500	48"	248,000 lbs	210,000 lbs	6.25"	7.45"	8.75"
6.025	4.000	60"	427,900 lbs	330,000 lbs	7.25"	8.90"	10.03"

Quick ship sizes built to fit your application have short lead times, 3", 4 1/2", 5 1/2", 6", 6 1/2", 7", and 8" bore sizes are available in 4 to 6 weeks. Other sizes can be manufactured per request.

This information is subject to change without notice or obligation.

For more information call 360-264-2141.